

製 造 規 格 Manufacturing Spec.

制訂日期 Establishment Date	2007/4/30	SS336SURWA/S530-A3/S290 製造規格 SS336SURWA/S530-A3/S290 Produce Spec.	文件編號 Doc. No.	CAGS-336-003
制訂部門 Establishment Dept.	工程 部 (CHRD1)		擬 案 Prepared by	李敬敬

SS335/6成品圖面(Finished Product Drawing)

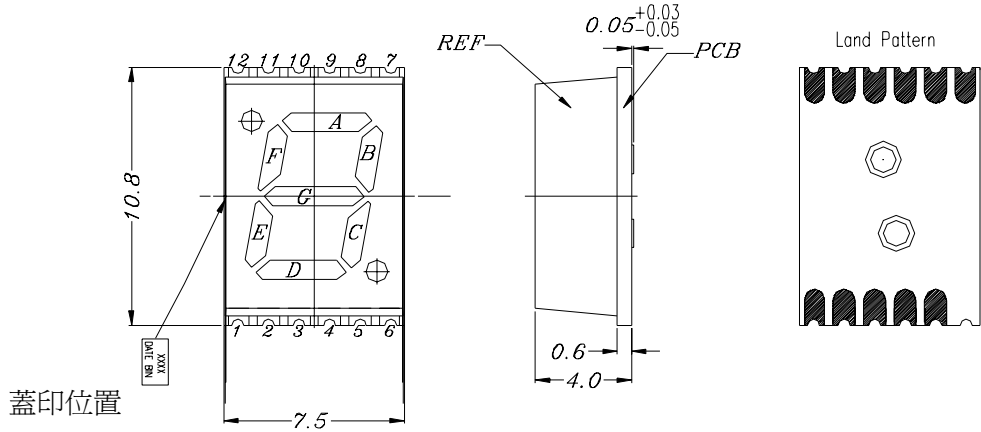

蓋印位置

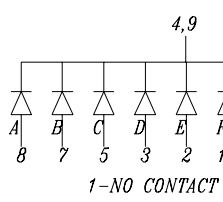

INTERNAL CONNECTION DIAGRM

- 1 NO CONTACT
- 2 ANODE E
- 3 ANODE D
- 4 COMMON CATHODE
- 5 ANODE C
- 6 ANODE DP1
- 7 ANODE B
- 8 ANODE A
- 9 COMMON CATHODE
- 10 ANODE F
- 11 ANODE DP2
- 12 ANODE G

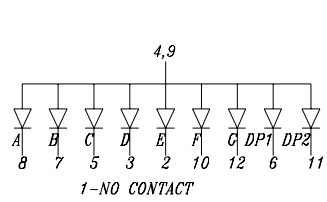

INTERNAL CONNECTION DIAGRM

- 1 NO CONTACT
- 2 CATHODE E
- 3 CATHODE D
- 4 COMMON ANODE
- 5 CATHODE C
- 6 CATHODE DP1
- 7 CATHODE B
- 8 CATHODE A
- 9 COMMON ANODE
- 10 CATHODE F
- 11 CATHODE DP2
- 12 CATHODE G

未標注尺寸均為±0.25mm:(TOLERANCES UNLESS DIMENSION ±0.25mm)

UNIT=mm

PS-SS336SUR的極性圖如下：

Drawing of PS-SS336SUR:

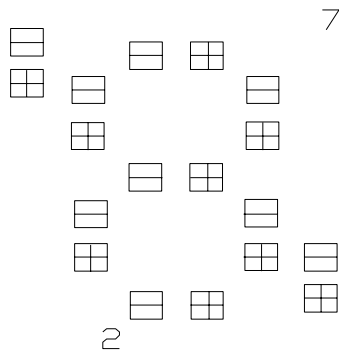

PS：標示正極為金線端，負極為晶片端.

變更註記 Changed Note	△	△	△	△	版 別 Rev.	2
年.月.日 Date	2007/4/30				頁 數 Page	1/8
工程變更(ECN)	ECN#2007/0234					

規格名稱 (Spec. Name)	SS336SURWA/S530-A3/S290 製造規格 SS336SURWA/S530-A3/S290 Produce Spec.	文件編號 (Doc. No.)	CAGS-336-003
----------------------	---	--------------------	--------------

一、工程流程圖 (Engineering flow chart)

材料名稱 (Materials name)	工程圖 (Engineering chart)	工程名稱 (Engineering name)	機械治工具 (Machinery patterns tools)	管理項目 (Managing items)	測定方法 (Testing method)
		進料檢驗 (Incoming inspect)		各材料承認書 (Materials approved specification)	
		倉儲管理 (Manage in storage)		溫度、時間、濕度 (Temperature Time Humidity)	溫、濕度計 (Hygrothermograph)
電路板(PCB) SMD (SUR)(SYG)		SMT(外)	刷錫膏治具/SMT機台/Reflow機台	溫度/時間 (Temperature/Time)	溫度計 Thermometer
		品管進料抽檢(IQA Select check)	45倍顯微鏡 (Microscope)	SMT位置、錫膏量 (SMT site, Tin quantity)	目視 (Visual inspection)
PS (PCB+SMD)		PS外觀全檢	45倍顯微鏡 (Microscope)	參照CAGS-ALL-010 (Reference CAGS-ALL-010)	目視 (Visual inspection)
		品管抽檢(PQC Select check)	45倍顯微鏡 (Microscope)	參照CAGS-ALL-010 (Reference CAGS-ALL-010)	目視 (Visual inspection)
反射蓋 (REF+A) 膠帶(TAPE)		排REF (Arranging REF)	Tray盤	方向 (Direction)	目視(Visual inspection)
A膠 (A epoxy)		配膠 (Distributing epoxy)	電子秤 (Electronic scale)	配膠比例(Mixing-epoxy proportion)	
B膠 (B epoxy)		抽真空(Pumping to vaccum)	真空機 (Vacuum machine)	溫度/時間 (Temprature/Time)	溫度計、計時器、 記錄表 (Thermometer/Hour meter/Record sheet)
擴散劑 (DP)		灌膠 (Encap)	自動灌膠機 (AUTO Filling epoxy machine)	膠量 (Epoxy amount)	
	轉下頁(TO next)				

變更注記 (Changed note)	△	△	△	△	△	版別(REV)	2
年月日(Date)	2007/4/30					頁次(Page)	2/8
工程變更(ECN)	ECN#2007/0234						

規格名稱 (Spec. Name)	SS336SURWA/S530-A3/S290 製造規格 SS336SURWA/S530-A3/S290 Produce Spec.	文件編號 (Doc. No.)	CAGS-336-003
----------------------	---	--------------------	--------------

材料名稱 (Materials name)	工程圖 (Engineering chart)	工程名稱 (Engineering name)	機械治工具 (Machinery patterns tools)	管理項目 (Managing items)	測定方法 (Testing method)
包裝材料 Materials for packing		目視雜物 (Removing impurity)	治具 (apparatus)	雜物、氣泡 (Impurity Air bubble)	目視(Visual inspection)
		短烤 (Short bake)	烤箱 (Oven)	溫度/時間 (Temprature/Time)	溫度計 計時器 (Thermometer/Hour meter)
		外觀 (Appearance)	刀片 (Knife)	多缺膠、溢膠、沾膠、氣泡、雜物 (glue、glue over flow、bubble、objects)	目視(Visual inspection)
		長烤	烤箱 (Oven)	溫度/時間 (Temperature/Time)	溫度計 計時器 (Thermometer/Hour meter)
		品管抽檢(PQC Select check)			
		組裝、熱壓 (Assembly、Heat Press)	熱壓治具 (Heat press apparatus)	熱壓點之平整性、REF及PCB之密合度 (The level of heat press point、REF and PCB airtight)	目視(Visual inspection)
		品管抽檢(PQC Select check)			
		電性/分光測試 (Eelectric testing/BIN grading)	AT測試机/ 8*8測試機 (AT testing machine & 8*8testing machine)	機台參數、亮度 (Machine parameter Luminous Intensity)	
		外觀 (Appearance)		雜物,氣泡,沾膠,溢膠 (object,bubble,glue,glue over flow)	目視(Visual inspection)
		品管抽檢(PQC Select check)			
		包裝 (Tapping)	Tapping 機 (Tapping machine)	標籤、數量、機種 (Label, quantity, part no.)	目視(Visual inspection)
		品管抽檢(PQC Select check)		參照製規 (Reference manufacture)	目視(Visual inspection)

○ 作業(Working process) ◇ 品管抽檢(PQC Select check) ▽ 材料投入 (Getting)

變更注記 (Changed note)	△	△	△	△	△	版別(REV)	2
年月日(Date)	2007/4/30					頁次(Page)	3/8
工程變更(ECN)	ECN#2007/0234						

規格名稱 Spec. Name	SS336SURWA/S530-A3/S290 製造規格 SS336SURWA/S530-A3/S290 Produce Spec.	文件編號 Doc. No.	CAGS-336-003
--------------------	---	------------------	--------------

二、材料明細(Meterals Name)：

供應商 Supplier	型號 Part No.	料號 Computer lot No.
諾華 HAPPY	PCB-SS336	9S81033525
吉華 LUCKY	SS336(REF+A)	8S41033510
億光 EVERLIGHT	16-213SURC/S347/TR8	3016237006
均旺 TEAM HOUSE	TAPE-25mm(3M-851)	9540250260
日東 NITTO	A EPOXY (NT-8000A)	9100180001
日東 NITTO	B EPOXY (NT-8000B)	9100280002
日東 NITTO	DP(NT-MB-D2X)	9100400001

三、SMT外包明細(SMT Meterals Name)：

供應商 Supplier	型號 Part No.	料號 Computer lot No.
威佳 GOOD WIN	PS-SS336SUR	8S110336E1

變更註記 Changed Note	△	△	△	△	版別 Rev.	2
年.月.日 Date	2007/4/30				頁數 Page	4/8
工程變更(ECN)	ECN#2007/0234					

規格名稱 Spec. Name	SS336SURWA/S530-A3/S290 製造規格 SS336SURWA/S530-A3/S290 Produce Spec.	文件編號 Doc. No.	CAGS-336-003
--------------------	---	------------------	--------------

四、SS336 BOM：

SS336 BOM

成品(Finished Product)

品名(name):SS336SURWA/S530-A3/S290
料號(material code):4U336E0022
用量(quantity):1 EA

品名(name):SS336SURWA(F/T)
料號(material code):8S61336E25
用量(quantity):1 EA

品名(name):SS336SUR (I/L)
料號(material code):8S310336E1
用量(quantity):1 EA

品名(name):SS336(REF+A+T+E)
料號(material code):8S71033500
用量(quantity):1 EA

品名(name):PS-SS336SUR
料號(material code):8S110336E1
用量(quantity):1 EA

品名(name):EPOXY-39.3+46.4+14.3
料號(material code):8S91400804
用量(quantity):0.12 G

品名(name):SS336(REF+A+T)
料號(material code):8S51033510
用量(quantity):1 EA

品名(name):PCB-SS335/6
料號(material code):9S81033525
用量(quantity):1 EA

品名(name):A膠(NT-8000A)
料號(material code):9100180001
用量(quantity):0.00039 KG

品名(name):Tape-25mm(3M-851)
料號(material code):9540250260
用量(quantity):0.00048 EA

品名(name):SS336(REF+A)
料號(material code):8S41033510
用量(quantity):1 EA

品名(name):16-213SURC/S347/TR8
料號(material code):3016237006
用量(quantity):9 EA

品名(name):B膠(NT-8000B)
料號(material code):9100280002
用量(quantity):0.00047KG

品名(name):DP(NT-MB-D2X)
料號(material code):9100400001
用量(quantity):0.00014 KG

品名(name):REF-SS336
料號(material code):9S21033525
用量(quantity):1EA

品名 (Part Name) 料號 (Computer Lot No.) 用量 (Quantity)

變更註記 Changed Note	△	△	△	△	版 別 Rev.	2
年.月.日 Date	2007/4/30				頁 數 Page	5/8
工程變更(ECN)	ECN#2007/0234					

規格名稱 Spec. Name	SS336SURWA/S530-A3/S290 製造規格 SS336SURWA/S530-A3/S290 Produce Spec.	文件編號 Doc. No.	CAGS-336-003
--------------------	---	------------------	--------------

五、一般生產規格文件(Common Produce Spec. Doc.) :

- | | |
|--|--|
| 1.配膠製造規格
Adjust glue operator specification | 文件編號 : CAGS-ALL-002
Doc. No. : CAGS-ALL-002 |
| 2.灌膠製造規格
Casting specification | 文件編號 : CAGS-ALL-003
Doc. No. : CAGS-ALL-003 |
| 3.短烤製造規格
Short curing specification | 文件編號 : CAGS-ALL-004
Doc. No. : CAGS-ALL-004 |
| 4.長烤製造規格
Pre curing operator specification | 文件編號 : CAGS-ALL-005
Doc. No. : CAGS-ALL-005 |
| 5.外觀檢驗製造規格
Appearance Check Operating Spec. | 文件編號 : AGS-ALL-006
Doc. No. : AGS-ALL-006 |
| 6.組裝、熱壓製造規格
Assembly、Heat press operator spec | 文件編號 : CAGS-ALL-007
Doc. No. : CAGS-ALL-007 |
| 7.後測(F/T)製造規格
F/T operator specification | 文件編號 : CAGS-ALL-008
Doc. No. : CAGS-ALL-008 |
- 分光等級(BIN Grading) IF=10mA

SS336SURWA/S530-A3/S290: BIN Grading; N,P,Q ,R,S.

蓋印方式如下 (Stamp items as Below.)

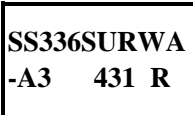

SS336SURWA/-A3 表品名(respect name)

"4" : Means :2004 Year;

31: 表示31周(means31 weekly)

"R" : Means :等級(Grading)

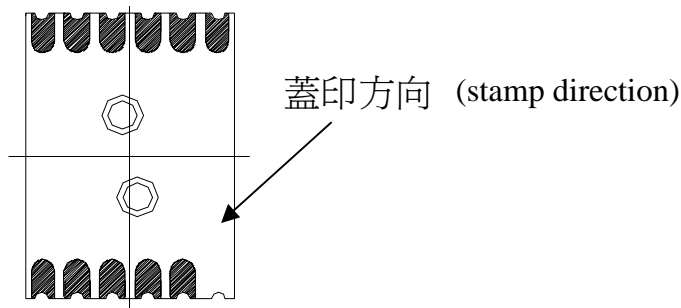

變更註記 Changed Note	△	△	△	△	版 別 Rev.	2
年.月.日 Date	2007/4/30				頁 數 Page	6/8
工程變更(ECN)	ECN#2007/0234					

規格名稱 Spec. Name	SS336SURWA/S530-A3/S290 製造規格 SS336SURWA/S530-A3/S290 Produce Spec.	文件編號 Doc. No.	CAGS-336-003
--------------------	---	------------------	--------------

8.成品包裝製造規格
Packing spec.

文件編號：CAGS-ALL-009
Doc. No.：CAGS-ALL-009

(8-1) 包裝規格如下：(package spec is below)
1卷1000PCS (1000PCS/Roll); 7卷裝一箱(7Rolls/Box),
前留21PCS; 后留40PCS.(Keep up 21PCS Before. Keep up 40PCS after.

(8-2) 此機種標籤打印參照 CSOP-3-194-D1
Label will be used to refer to CSOP-3-194-D1.

9.SMT外包半成品檢驗製造規格文件編號：CAGS-ALL-010

SMT half-product inspect spec Doc. No.：CAGS-ALL-010

變更註記 Changed Note	△	△	△	△	版 別 Rev.	2
年.月.日 Date	2007/4/30				頁 數 Page	7/8
工程變更(ECN)	ECN#2007/0234					

規格名稱 Specification name	SS336SURWA/S530-A3/S290 製造規格 SS336SURWA/S530-A3/S290 Produce Spec.	文件編號 Doc.no.	CAGS-336-003
----------------------------	---	-----------------	--------------

文件修改記錄(Device to amend record) :

版別(Rev.)	修改日期 To Amend Date	文件修改內容 Device To Amend Content	備註 Notes
2	2007/4/30	增加PS極性圖 Add drawing of PS	自行變更 Change itself

針對其工程變更項目內容加注其處理對策 (Add the treatment strategy to the item of engineering change)

處理方式(Treatment):

項目代號(Item)	處理對策(Treatment strategy)

代號(Item) a. 舊材料處理方式 b. WIP c. 舊庫存
(a. Treatment of original material b. WIP c. Original storage)

變更註記 modify recode	△	△	△	△	△	版別 REV	2
年、月、日 year monuth day	2007/4/30					頁數 page	8/8
工程變更(ECN)	ECN#2007/0234						