

典型性能 Features

- ◆ 50-150 瓦功率输出 (50-150 Watts of Output Power)
- ◆ 超宽电压输入 (4:1 Wide Range Input)
- ◆ 长期短路保护, 自恢复 (Short Circuit Protection, Automatic Recovery)
- ◆ 小型化封装 (Small Package)



电气特性 Electrical Specifications

输入特性 Input	Min	Type	Max	Notes
输入电压范围	9V	24V	36V	9-36V输入范围尾缀加W
Input Voltage Range	66V	110V	160V	40-160V输入范围尾缀加W
控制功能 ON/OFF Control	正逻辑	ON		CNT 悬空或接TTL高电平 CNT pin left open or CNT pin connected to TTL logic high
		OFF		CNT 与-Vin 相连 CNT pin is at a logic low
	负逻辑 尾缀 P	ON		CNT 与-Vin 相连 CNT pin is at a logic low
		OFF		悬空或接TTL高电平 CNT pin left open or CNT pin connected to TTL logic high
逻辑低 Logic Low			1.2V	
输入欠压保护 Input. Under-voltage Lockout	6		9	9-36V输入
	30V		43V	40-160V输入
	55V		66	66-160V输入
启动延时时间 Start-up Delay Time		10mS		
输出特性 Output	Min	Type	Max	Notes
输出电压精度 Set point Accuracy		±1%	±3%	
负载效应 Load Regulation		±0.5%	±1%	
源效应 Line Regulation		±0.2%	±1%	
输出电压调节 TRIM Range			±10%	
动态响应 Dynamic Response			4%Vo Pk deviation 100μS settling time	50~75% load 50~25% load
温度系数 Temperature Regulation		±0.2%/°C		

温度系数 Temperature Regulation		±0.2%/°C			
输出过流保护 Current Limit Threshold	110%		160%		
输出过压保护 Over-voltage Protection	110%		140%		
短路保护 Short-Circuit Protection	长期短路自恢复 Continuous, Automatic Recovery				
综合特性 General		Min	Type	Max	
隔离电压 Isolation Voltage	标准型	1500Vac			Input to Output
	加强型	2000Vac			Input to Output(尾缀T)
	标准型	1500Vac			Input to Case
	加强型	2000Vac			Input to Case(尾缀T)
	标准型	500Vac			Output to Case
	加强型	500Vac			Output to Case (尾缀T)
绝缘电阻 Isolation Resistor (500VDC)	100MΩ				Input to Output
开关频率 Switching Frequency		300KHz			
平均故障间隔时间 MTBF		2×10 ⁶ Hrs			Mil HDBK 217F Tc=25°C
工作壳温 Case Temperature	-40°C		+100°C		
储存温度 Storage Temperature	-55°C		+125°C		
相对湿度 Relative Humidity	10%		90%		
管脚焊接温度 Pin Solder Temperature			250°C		Wave Solder <10S
手工焊接时间 Hand Soldering Time			5S		Iron Temperature 425 °C
传导 Conducted Emission	GB9254/CISPR22/EN55022 Class A (推荐电路见图)				
静电放电 Electrostatic Discharge	GB17626/EN61000-4-2 Contact ±4KV air ±8KV				
浪涌抗扰度 Surge Immunity	GB17626/EN61000-4-5 ±2KV (推荐电路见图) perf. Criteria A				
脉冲群抗扰度 Electrical Fast Transient	GB17626/EN61000-4-4 ±2KV (推荐电路见图) perf. Criteria A				

型号 Models	输入电压范围 Input Voltage Range	输出电压 (Vdc) Output Voltage	输出电流 (A) Output current	纹波噪声(mv) Ripple and noise	典型效率 Efficiency	容性负载 (μF) Max.Capacitor Load
WRQ50-24S3V3W	9-36	3.3	15	150	90%	10000
WRQ50-24S5W	9-36	5.05	10	150	91%	10000
WRQ50-24S12W	9-36	12	4.17	150	91%	2200
WRQ50-24S13V8W	9-36	13.8	3.62	150	90%	2200
WRQ50-24S15W	9-36	15	3.33	150	90%	2200
WRQ50-24S24W	9-36	24	2.08	150	90%	1000
WRQ50-24S48W	9-36	48	1.04	400	89%	470
WRQ75-24S3V3W	9-36	3.3	22	150	90%	10000
WRQ75-24S5W	9-36	5.05	15	150	91%	10000
WRQ75-24S12W	9-36	12	6.25	150	89%	2200
WRQ75-24S13V8W	9-36	13.8	5.43	150	90%	2200
WRQ75-24S15W	9-36	15	5	150	90%	2200
WRQ75-24S24W	9-36	24	3.13	150	90%	1000
WRQ75-24S48W	9-36	48	1.56	400	89%	470
WRQ100-24S5W	9-36	5.05	20	150	91%	10000
WRQ100-24S12W	9-36	12	8.33	150	89%	2200
WRQ100-24S13V8W	9-36	13.8	7.25	150	90%	2200
WRQ100-24S15W	9-36	15	6.67	150	90%	2200
WRQ100-24S24W	9-36	24	4.17	150	90%	1000
WRQ100-24S48W	9-36	48	2.08	400	89%	470
WRQ150-24S5W	9-36	5.05	30	150	91%	10000
WRQ150-24S12W	9-36	12	12.5	150	90%	2200
WRQ150-24S13V8W	9-36	13.8	10.9	150	90%	2200
WRQ150-24S15W	9-36	15	10	150	90%	2200
WRQ150-24S24W	9-36	24	6.25	150	90%	1000
WRQ150-24S48W	9-36	48	3.13	400	90%	470
WRQ50-110S5	66-160	5.05	10	150	91%	10000
WRQ50-110S12	66-160	12	4.17	150	89%	2200
WRQ50-110S13V8	66-160	13.8	3.62	150	90%	2200

WRQ50-110S15	66-160	15	3.33	150	90%	2200
WRQ50-110S24	66-160	24	2.08	150	90%	1000
WRQ50-110S48	66-160	48	1.04	400	89%	470
WRQ50-110S5W	40-160	5.05	10	150	90%	10000
WRQ50-110S12W	40-160	12	4.17	150	89%	2200
WRQ50-110S13V8W	40-160	13.8	3.62	150	89%	2200
WRQ50-110S15W	40-160	15	3.33	150	89%	2200
WRQ50-110S24W	40-160	24	2.08	150	90%	1000
WRQ50-110S48W	40-160	48	1.04	400	89%	470
WRQ75-110S5	66-160	5.05	15	150	91%	10000
WRQ75-110S12	66-160	12	6.25	150	89%	2200
WRQ75-110S13V8	66-160	13.8	5.43	150	90%	2200
WRQ75-110S15	66-160	15	5	150	90%	2200
WRQ75-110S24	66-160	24	3.13	150	90%	1000
WRQ75-110S48	66-160	48	1.56	400	89%	470
WRQ75-110S5W	40-160	5.05	15	150	91%	10000
WRQ75-110S12W	40-160	12	6.25	150	89%	2200
WRQ75-110S13V8W	40-160	13.8	5.43	150	89%	2200
WRQ75-110S15W	40-160	15	5	150	89%	2200
WRQ75-110S24W	40-160	24	3.13	150	90%	1000
WRQ75-110S48W	40-160	48	1.56	400	89%	470
WRQ100-110S5	66-160	5.05	20	150	91%	10000
WRQ100-110S12	66-160	12	8.33	150	89%	2200
WRQ100-110S13V8	66-160	13.8	7.25	150	90%	2200
WRQ100-110S15	66-160	15	6.67	150	90%	2200
WRQ100-110S24	66-160	24	4.17	150	90%	1000
WRQ100-110S48	66-160	48	2.08	400	90%	470
WRQ100-110S5W	40-160	5.05	20	150	91%	10000
WRQ100-110S12W	40-160	12	8.33	150	89%	2200
WRQ100-110S13V8W	40-160	13.8	7.25	150	89%	2200

WRQ100-110S15W	40-160	15	6.67	150	89%	2200
WRQ100-110S24W	40-160	24	4.17	150	90%	1000
WRQ100-110S48W	40-160	48	2.08	400	89%	470
WRQ150-110S5	66-160	5.05	30	150	91%	10000
WRQ150-110S12	66-160	12	12.5	150	90%	2200
WRQ150-110S13V8	66-160	13.8	10.9	150	90%	2200
WRQ150-110S15	66-160	15	10	150	90%	2200
WRQ150-110S24	66-160	24	6.25	150	90%	1000
WRQ150-110S48	66-160	48	3.13	400	90%	470
WRQ150-110S5W	40-160	5.05	30	150	91%	10000
WRQ150-110S12W	40-160	12	12.5	150	90%	2200
WRQ150-110S13V8W	40-160	13.8	10.9	150	90%	2200
WRQ150-110S15W	40-160	15	10	150	89%	2200
WRQ150-110S24W	40-160	24	6.25	150	88%	1000
WRQ150-110S48W	40-160	48	3.13	400	88%	470

■说明：仅列出典型型号，其它型号，请确定功率，输入电压及输出电压，致电我公司。

磁兼容应用 (EMC)

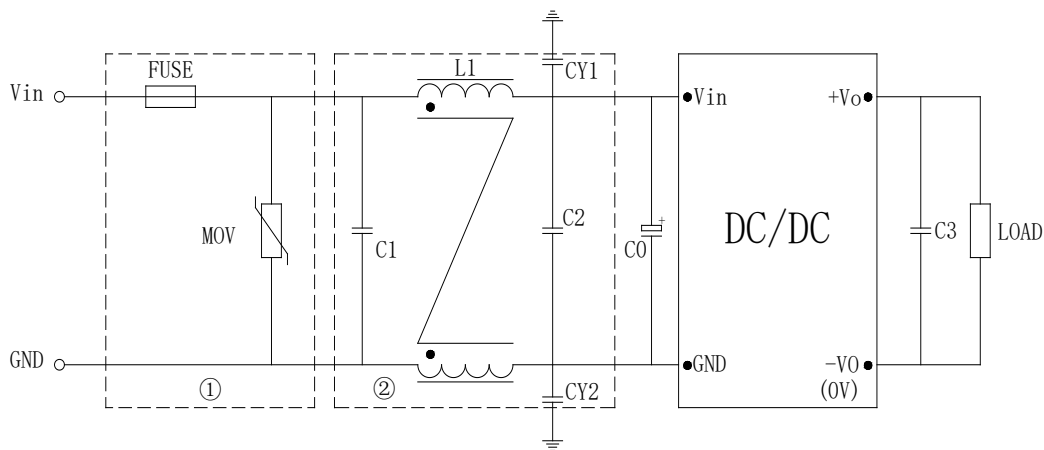

FUSE:推荐采用慢熔型的产品，FUSE 电流选择要考虑高温降额和冲击电流的影响。

MOV:压敏电阻，MOV 可以和保险丝串联应用，防止 MOV 失效。也可以两只 MOV 串联，增加可靠性。

C0 C3:高频电解电容

C1 C2:高频独石电容或者薄膜电容。

LCM:共模电感。具体型号请咨询销售人员。

CY1 CY2:安规 Y2 电容

型号	Vin: 24V	Vin: 48V	Vin: 110V
FUSE	4A 慢熔	2A 慢熔	2A 慢熔
MOV	14D101K	14D101K	14D201K
C0	100μF/50V	47μF/100V	47μF/250V
C1、C2	4.7μF/50V	2.2μF100V	1μF250V
C3	100μF		
LCM	3mH		
CY1、CY2	4.7nF Y2 安规电容		

输出调节应用 (TRIM Function)

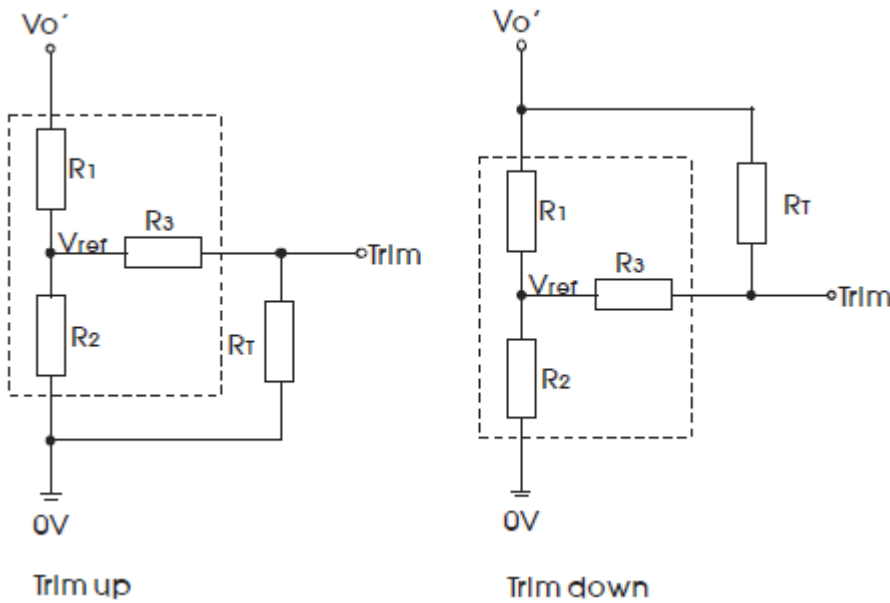

$$up: R_T = \frac{TR_2}{R_2 - T} - R_3 \quad T = \frac{V_{ref}}{V_{o'} - V_{ref}} \cdot R_1 \text{ (调高电压)}$$

$$down: R_T = \frac{TR_1}{R_1 - T} - R_3 \quad T = \frac{V_{o'} - V_{ref}}{V_{ref}} \cdot R_2 \text{ (调低电压)}$$

Vout (V)	R1(KΩ)	R2(KΩ)	R3(KΩ)	Vref(V)
3.3	3.32	2.0	8.2	1.24
5	2.55	2.49	8.2	2.5
9	6.49	2.49	10	2.5
12	9.53	2.49	12	2.5
13.8	11.31	2.49	12	2.5
15	12.5	2.49	15	2.5
24	21.5	2.49	20	2.5
28	25.5	2.49	20	2.5
48	45.3	2.49	20	2.5

机械图及管脚说明 (Mechanical Chart、Pins) (Unit: mm/inch)

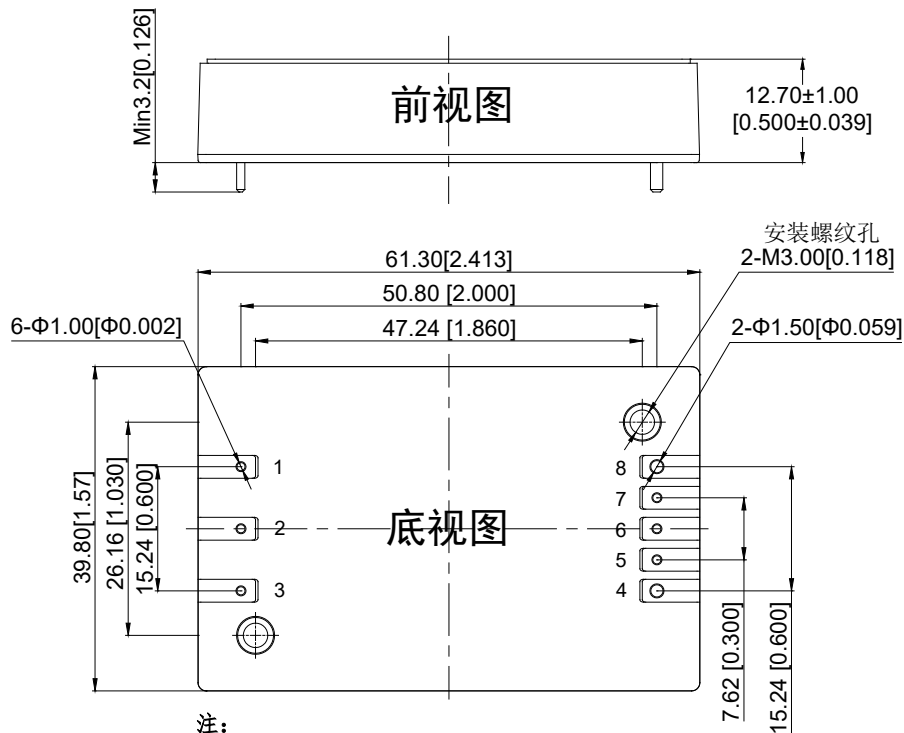

注:

尺寸单位:mm[inch]

未注尺寸公差: ±0.50[±0.020]

未注直径公差: ±0.10[±0.004]

管脚 Pin	1	2	3	4	5	6	7	8
功能 Function	-Vin	CNT	+Vin	+Vo	+S	TRIM	-S	-Vo

注:安装定位尺寸公差按 GB/T1804-2000 F 级标准、外型尺寸公差按 GB/T1804-2000 C 级标准,尾缀带 V 人产品没有螺纹,提供通孔产品。

散热器提供 12.7mm 和 25.4mm 两种尺寸,特殊散热器向销售详询。